

Laun

MASCHINEN- UND APPARATEBAU GMBH

WALDSTRASSE 71
 D-65451 KELSTERBACH
 GERMANY
 TELEFON: +49-6107-98669-0
 TELEFAX: +49-6107-98669-20
 INTERNET: www.laun-online.com
 EMAIL: info@laun-online.com

DOUBLE PENDULUM FLAP HT

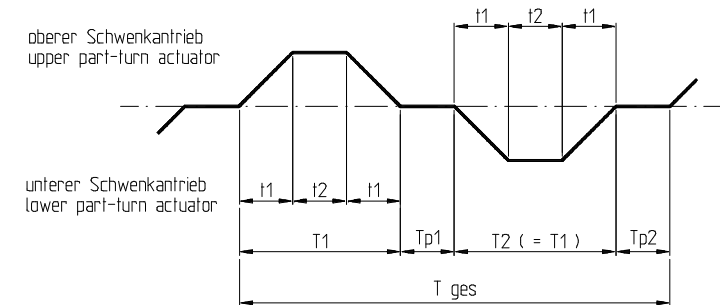
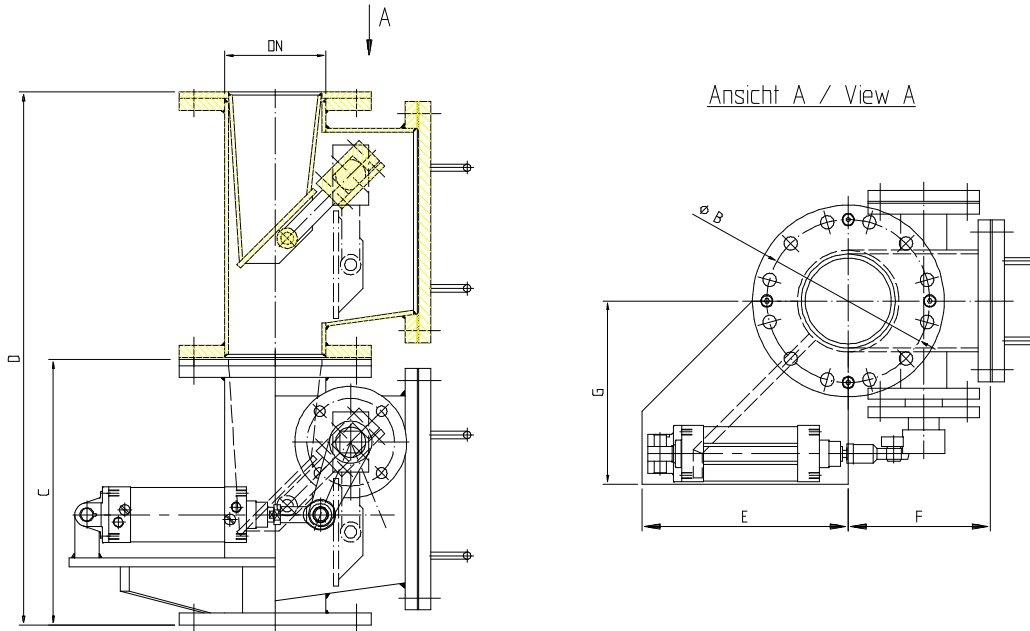

t1 = Opening and closing time
 t2 = time „open“
 Tp1 = pause between the cycles of the single pendulum valves
 Tp2 = pause after a whole cycle of the double pendulum valve

- Materials and connecting dimensions acc. to customer requirements.
- Max. temperature ca. 750 ° C.
- If required pressure vessel codes are considered
- Optional Labyrinth-sealing (for high Δp (between in- and outlet)
- All types of actuators possible
- Various operation controls possible

DN	A	B	C	D	E	F	G	H	VOLUME PER CYCLE [L]
150	Ø168	Ø240 (8xØ22)	440	885	360	235	310	185	3,2
200	Ø 219	Ø295 (8xØ22)	470	945	390	260	340	210	9,0
250	Ø 273	Ø350 (12xØ22)	510	1025	480	305	370	240	12,5
300	Ø 323	Ø400 (12xØ22)	545	1095	650	335	400	265	19,0

(subject to change without notice)